



HAL
open science

Machine tool architecture selection at the preliminary design stage: application to hard material machining

Montassar Lajili, H el ene Chanal, Belhassen-Chedli Bouzgarrou

► To cite this version:

Montassar Lajili, H el ene Chanal, Belhassen-Chedli Bouzgarrou. Machine tool architecture selection at the preliminary design stage: application to hard material machining. *Journal of Computational Design and Engineering*, 2020, 7 (5), pp.657 - 667. 10.1093/jcde/qwaa049 . hal-02667831

HAL Id: hal-02667831

<https://uca.hal.science/hal-02667831v1>

Submitted on 12 Nov 2020

HAL is a multi-disciplinary open access archive for the deposit and dissemination of scientific research documents, whether they are published or not. The documents may come from teaching and research institutions in France or abroad, or from public or private research centers.

L'archive ouverte pluridisciplinaire **HAL**, est destin ee au d ep ot et  a la diffusion de documents scientifiques de niveau recherche, publi es ou non,  emanant des  tablissements d'enseignement et de recherche fran ais ou  trangers, des laboratoires publics ou priv es.



Distributed under a Creative Commons Attribution 4.0 International License

RESEARCH ARTICLE

Machine tool architecture selection at the preliminary design stage: application to hard material machining

Montassar Lajili, H el ene Chanal * and Belhassen Chedli Bouzgarrou

Universit e Clermont Auvergne, CNRS, SIGMA Clermont, Institut Pascal, F-63000 Clermont–Ferrand, France

*Corresponding author. E-mail: helene.chanal@sigma-clermont.fr  <http://orcid.org/0000-0001-5738-7195>

Abstract

The preliminary design stage ensures to evaluate machine tool performances according to the simulation of reduced models. Performance criteria are defined regarding the attempted machining process requirements. In our case, we study the problem of machine tool design for hard metal cutting, where a high level of stiffness is required. In this context, this paper's aim is to introduce a new methodology of machine tool architectures modeling, optimization, and selection with regards to their stiffness and dynamic performances at the preliminary design stage. However, this type of study requires a quantitative evaluation of performance indicators. Studied machine tool structures are modelled with simplified shape parts. The dimensions of these parts are defined as design variables. Afterward, for each considered architecture, parametric design optimization is performed to minimize its mass under the constraint of a minimal attempted stiffness all over the workspace. This approach allowed restricting the total number of machine tool architectures to be detailed further and analyzed more accurately. In a first time, the paper includes an illustration of the developed methodology through an example of machine tool architecture evaluation and optimization. In a second time, the method is used to compare different kinds of machine tool architectures regarding their ability to be light for an attempted stiffness.

Keywords: machine tool; modeling; preliminary design; parametric optimization; static and modal analyses

1. Introduction

Performance requirements for machine tools have evolved significantly over the past decade. Productivity and quality requirements for hard material parts have increased considerably. This evolution is mainly due to the expansion of titanium alloys used in the aeronautical industry (Inagaki, Takechi, Shirai, & Ariyasu, 2014; Rodrigues Henriques, de Campos, Alves Cairo, & Bresiani, 2005). Indeed, titanium alloys are widely used for structural aeronautical components to optimize the performance in terms of mass, corrosion resistance, and mechanical behavior (Inagaki et al., 2014; Wagner, 2011).

Low cutting speeds and high cutting forces characterize titanium alloys machining (Wagner, 2011). High cutting forces coupled with low rotational frequencies of the spindle can produce large deflections of the machine tool structure. Thus, static

behavior must be controlled during the design stage (Huo & Cheng, 2009; Maj, Modica, & Bianchi, 2006; Mori, Piner, Ding, & Hansel, 2008).

In the preliminary design stage of a machine tool, the performance criteria of different architecture designs should be estimated based on reduced models and according to machining process conditions. This analysis reduces the number of solutions that must be analyzed more accurately. To conduct this quantitative evaluation study, reduced models and performance indicators should be defined (Mekid, 2009).

Widely used performance criteria are (Bouzgarrou, 2001; Chanal, Duc, & Ray, 2006) geometric workspace, dexterity, accuracy, stiffness, and dynamic behavior. Dehong considers that hard metal cutting needs a machine tool static stiffness around 500 N/ μm (Huo & Cheng, 2009).

Received: 19 January 2020; Revised: 30 April 2020; Accepted: 4 May 2020

  The Author(s) 2020. Published by Oxford University Press on behalf of the Society for Computational Design and Engineering. This is an Open Access article distributed under the terms of the Creative Commons Attribution License (<http://creativecommons.org/licenses/by/4.0/>), which permits unrestricted reuse, distribution, and reproduction in any medium, provided the original work is properly cited.

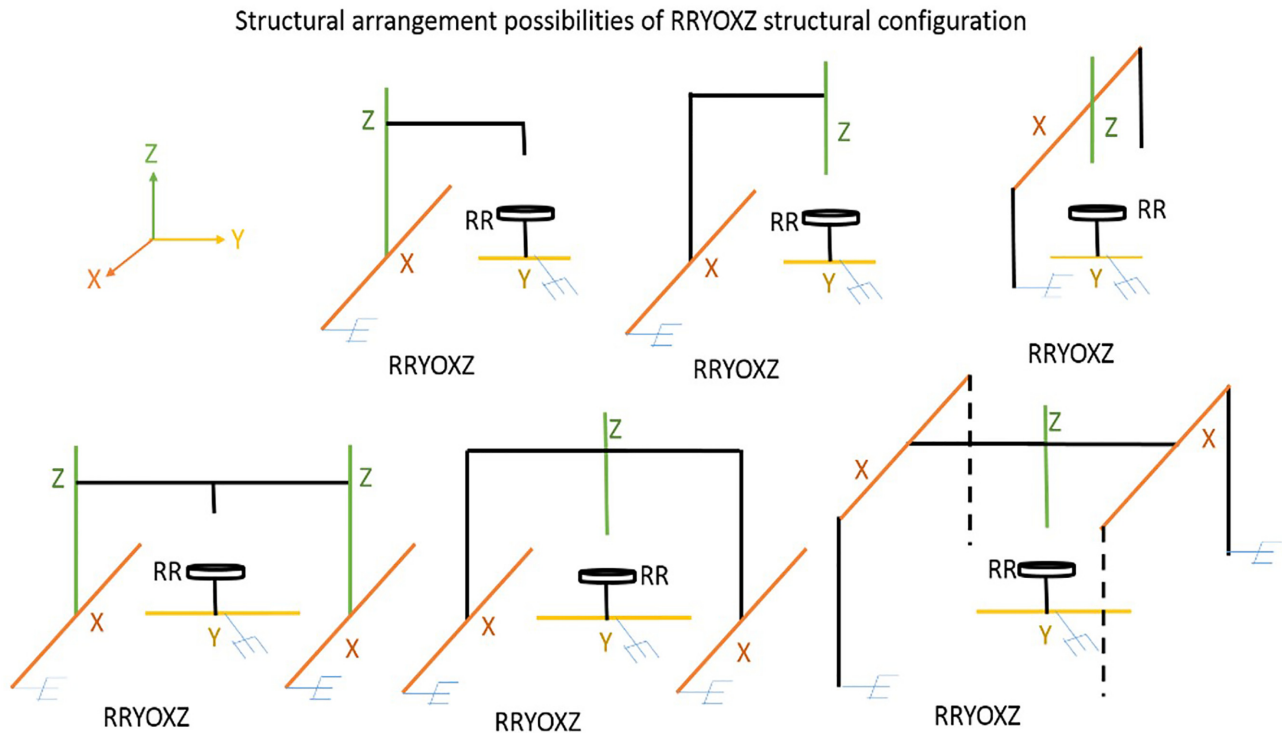

Figure 1: Several architectures associated with the structural configuration RRYOXZ.

Authors conducted a previous published study to select the 5-axis machine tool architectures that are relevant for machining aeronautical titanium alloy parts (Lajili, Chanal, Bouzgarrou, & Duc, 2017). They proposed a first sorting based on the literal expression of required technical constraints. The evaluation involves assigning a point when an architecture respects a given functional constraint. The obtained score allows classifying the architectures according to an attempted machining process. The application of this methodology of synthesis and choice of structural configurations in the case of a 5-axis machine tool for machining titanium alloy aeronautical parts enables selecting 32 configurations from 2160 possibilities. However, as shown in Fig. 1, a structural configuration can be designed with different structural arrangements. A quantitative comparison of architectures regarding stiffness constraints and mass minimization must be conducted.

In this paper, we present a methodology for selecting the most appropriate machine tool structural arrangement for a specific cutting operation (in our case, titanium alloys machining) during the preliminary design phase. The particularity of our approach lies in the fact that we consider several arrangements of machine tool mechanical structures. Studied structures are modeled, analyzed, and optimized in terms of mass and stiffness. The choice of the modeling approach is motivated by the high level of stiffness requirement (500 N/ μm in our case). In this context, beam elements cannot model the machine tool parts as in Koenigsberger and Tlustý (1970).

The goal of this article is then to propose a methodology that allows selecting relevant machine tool kinematic architecture regarding their ability to be stiff and light. Thus, our methodology must ensure to be applied simply for different kinds of architectures with high stiffness requirements and to be fast and accurate enough to be employed in the preliminary design stage to tend the machine tool weight for an attempted stiffness.

In the following section, we introduce the different approaches for modeling the mechanical behavior of machine tool. After, we discuss the proposed selection process and performance evaluation criteria. Then, we define the design parameters used for the development of reduced models of machine tool structures. Afterward, we describe the used optimization process. Finally, we present results obtained by the application of the developed methodology.

2. Mechanical Behavior Modeling of Machine Tool

Machine tool builders give great interest to simulation means. Indeed, virtual studies of machine static and dynamic behavior ensure to increase their performances while decreasing design time (Altintas, Brecher, Weck, & Witt, 2005). These simulations are based on a mechanical model of a machine tool structure. Modeling methods are classified into two categories: multibody model (MBM) and finite element model (FEM).

2.1. Multibody model

MBM is reputed to be fast and efficient. Beams or/and local stiffness/damping elements model the machine tool structural elements. This model can be coupled with a kinematic description to change the configuration of the studied machine tool (Portman, Shneur, Chapsky, & Shapiro, 2014).

Slavković uses MBM for optimizing vibration isolation of machine tool (Slavković et al., 2015). Kono has developed an evaluation methodology (Axis Construction Kit) of machine tool configurations based on MBM (Kono, Lorenzer, Weikert, & Wegener, 2010a). Zirn applies MBM on machine tool by considering the control axis as a subsystem (Zirn, 2008).

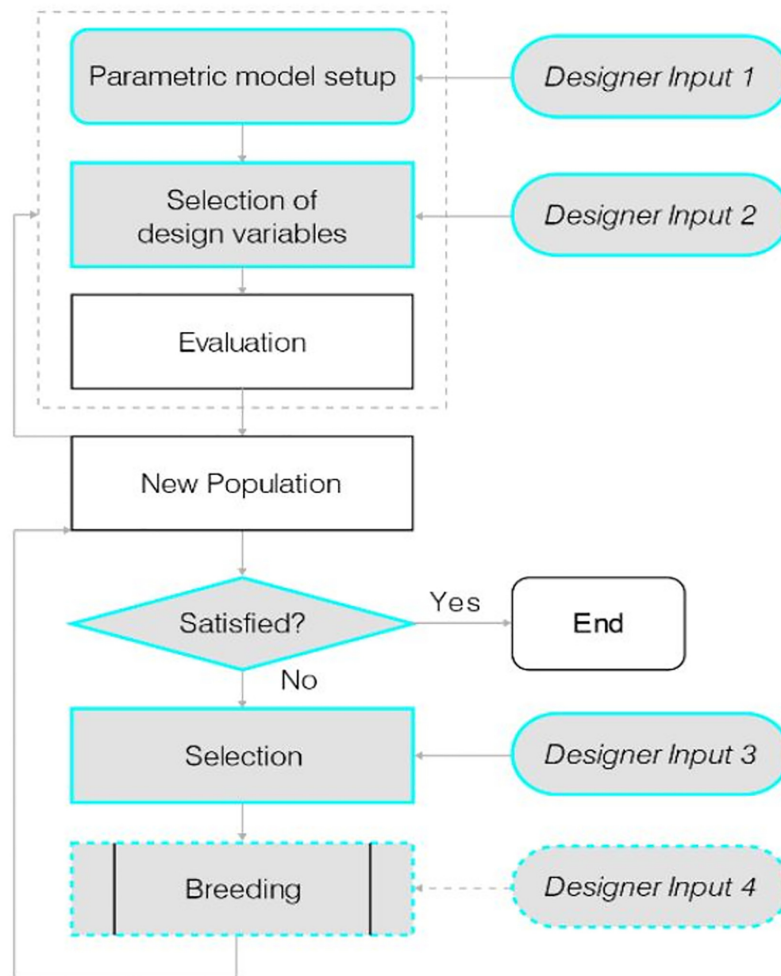

Figure 2: Optimization process defined by Danhaive (Danhaive & Mueller, 2015).

MBM benefit lies in the significant decrease of the model DOFs compared to the FEM. According to Altintas, the use of MBM is relevant for defining fast and approximative simulation results (Altintas et al., 2005).

2.2. Finite element model

For several years, FEM has been used for analysing the mechanical behavior of machine tool. For example, Bouzgarrou employed a FEM for dimensioning a new machine tool dedicated to high-speed machining (Bouzgarrou, 2001).

From a relevant definition of parameters and meshing of each structural element, an FEM ensures to predict the mechanic behavior of a machine tool accurately. FEM can be used to design a machine tool structure regarding the interaction between the parts, the tool, and the machine (Hung, Lai, Lin, & Lo, 2011; Mori et al., 2008; Zulaika, Campa, & Lopez De Lacalle, 2011).

However, the simulation of a machine tool structure by FEM can take a long time regarding the high number of DOFs. Thus, model solving takes a significant time regarding machine tool design time (Zatarain, Lejardi, & Egaña, 1998).

2.3. Summary

To develop predictive and fast models for the evaluation and the optimization of several machine tool architectures, in the

preliminary design stage, we propose, in this work, a reduced FEM approach to simplify model definition. Model reduction is based on a simplification of part shapes.

In the context of the preliminary design stage, the machine tool structures are simplified and modeled with box-shaped parts with shell structural elements and joint stiffness (Kono, Lorenzer, Weikert, & Wegener, 2010b). The dimensions of these parts and positions of joint are parameterized and defined as design variables. Coupling a constrained optimization algorithm, using a Matlab function, with the FEM analysis, in ANSYS, for stiffness evaluations ensures to perform the design optimization. After that, optimized solutions are compared according to their performances to select the most relevant structure.

3. Parametric Design of a Machine Tool Structure

Parametric design is largely used during the preliminary design stage (Li, Hong, Wang, Wu, & Chen, 2012). The definition of the parametric model ensures to simplify the modification of structure dimensions and the optimization process. For example, Li parameterizes the bed structure of a machine tool. The optimization of the variable parameters allows increasing the bed structure rigidity and reduces the maximal deformation by 19% (Li et al., 2012).

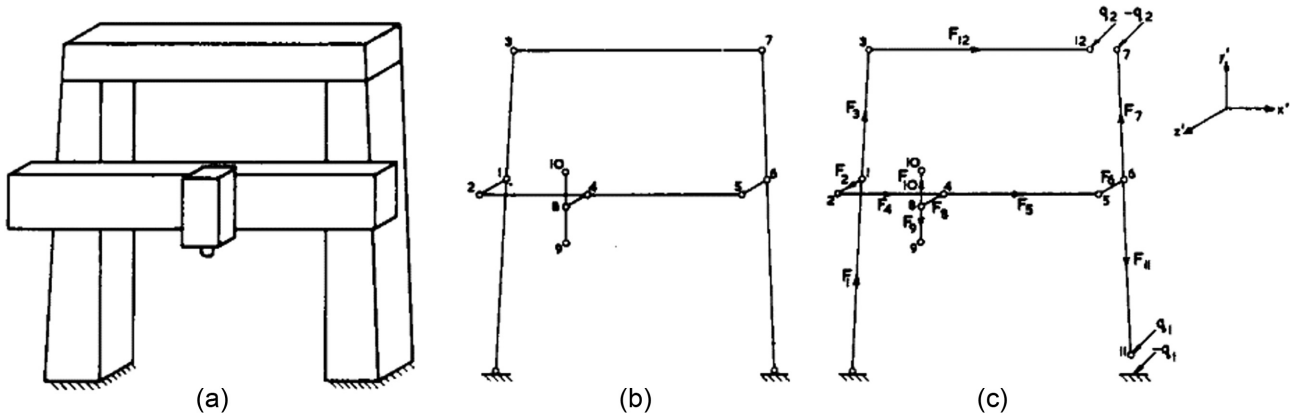

Figure 3: A reduced model of a milling machine (Koenigsberger & Tlustý, 1970).

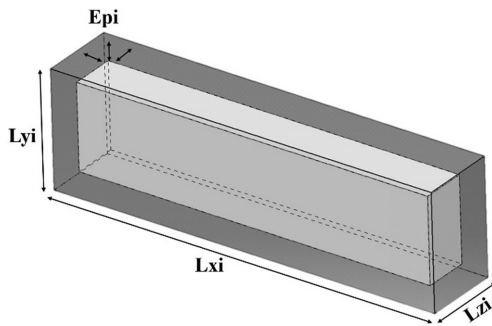

Figure 4: Parameterized hollow parallelepiped shape.

In Danhaive's work, the parametric modeling associated with optimization is used to propose a stiffer mechanical structure while decreasing total mass (Danhaive & Mueller, 2015). Figure 2 illustrates the optimization process.

Koenigsberger presented a structural analysis of machine tool based on a reduced model (Koenigsberger & Tlustý, 1970). Beam elements model each structural element (Fig. 3). However, in our case study, we choose not to use this approach due to the high attempted stiffness. Indeed, beam cross-section dimensions become too large regarding the beam lengths due to the high values of stiffness. Thus, the beam theory hypothesis is no longer verified.

Thus, Kono proposed a model of machine tool structural elements with parallelepiped shape (Kono et al., 2010b). The obtained result is close to the experimentally measured behavior. In the same context, Li developed an optimization of a machine tool bed structure for green machining (Li et al., 2012). In this method, a hollow box-shaped structure models the machine tool structure.

Thus, according to this literature review, we choose to model machine tool structure elements with hollowed parallelepiped shapes (Fig. 4).

Four parameters characterize a parallelepiped shape i . They are the length L_{xi} , the height L_{yi} , the width L_{zi} , and the thickness E_{pi} . The length L_{xi} is fixed regarding the workspace size. Thus, only three parameters L_{yi} , L_{zi} , and E_{pi} , are defined as design variables for the optimization process for each substructure. The next section introduces the structure parameterizing and the adopted design language.

3.1. FE modeling

In his Ph.D. work, Maglie shows the benefit of a parameterized design during the preliminary design stage. He uses the parametric design language of ANSYS software, "Ansys Parametric Design Language (APDL)" (Maglie, 2012). In APDL language, a .txt file composed of several command lined defines design parameters, design variables, each part geometry, materials, meshing, loads, boundary conditions, types of simulation, and results of a mechanical structure.

In this work, parametric design language APDL is chosen. In a first time, the study is focused on the comparison of two types of machine tool structures (an open-loop structure and a closed-loop structure) for the same workspace size ($z = 2$ m, $y = 2$ m). These two architectures are composed of three substructures. Three design variables define each substructure (Fig. 5).

In this first study, we consider a rigid contact between each substructure. The first substructure is fixed on the ground. The position of the second substructure can be modified along the Z-axis and the Y-axis for the third substructure. Neglecting the influence of the position along the X-axis ensures to study the behavior of the machine tool all over the workspace. Consequently, simulations are only realized for different tool positions in the Y-Z plane.

Even if there are size variations of each substructure, models are generated to have always the same workspace size. Each substructure is defined from the envelope plan and meshing with shell elements ("Shell81" in ANSYS) (Fig. 6). The surfaces are defined in such a way that the regularity of the mesh is guaranteed, which enables them to have regular meshes and good element quality.

3.2. Summary

In our modeling methodology, we apply two simplifications. The first consists of modeling each substructure by hollow parallelepiped shape. The second concerns the use of rigid joints between substructure elements. In that way, we obtain an approximate estimation of the performance indicator values. Simulation results should be used just for orientating the structure choice in the preliminary design stage of a machine tool.

In the following section, the optimization process and performance criteria are detailed.

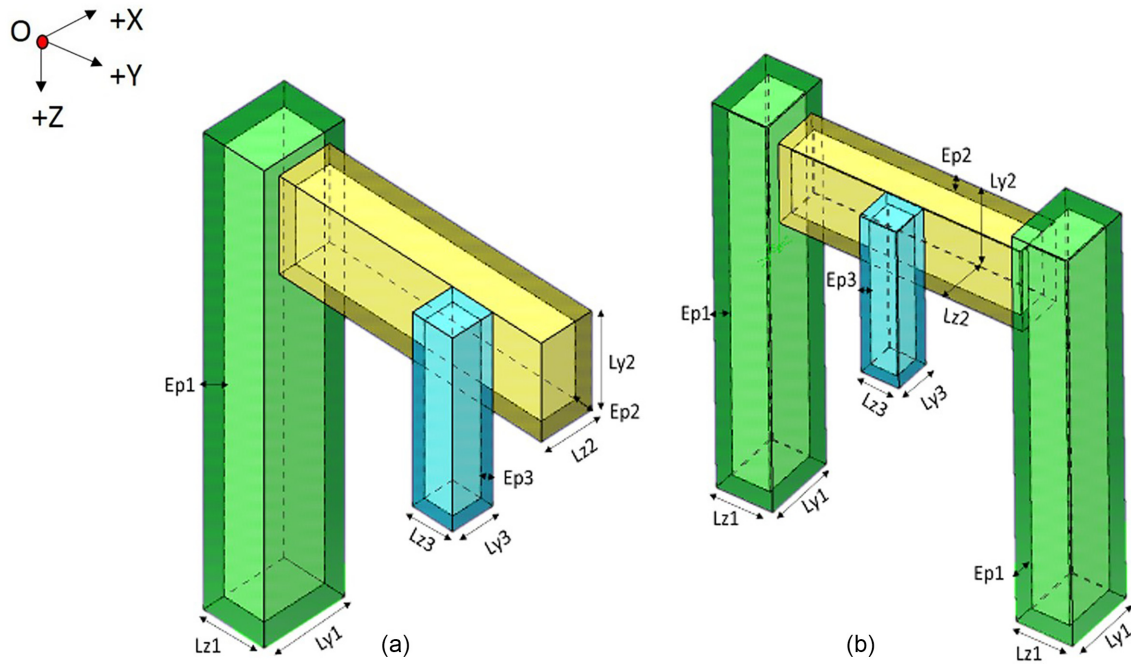

Figure 5: Parametric model of an open-loop architecture (a) and closed-loop architecture (b).

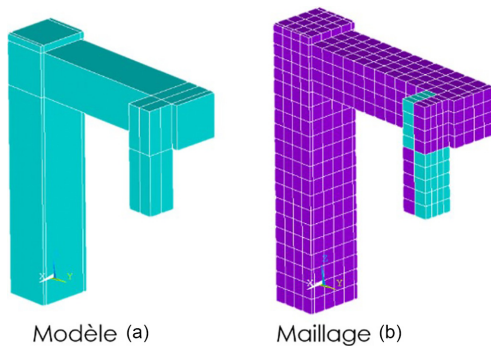

Figure 6: APDL model of the open-loop architecture (a) and its meshing (b).

4. The Quantitative Criteria-Based Selection Process

In the preliminary design stage, machine tool structures are simplified and modeled by an association of substructures. A parametric reduced model represents each substructure. The simulation of these reduced models ensures to evaluate the performance of the machine tool architecture.

Thus, in this paragraph, we firstly define the different steps of our selection process before introducing performance criteria.

4.1. Selection process

Our selection process is composed of four steps (Fig. 7). The first step consists in defining the parameterized reduced models of the studied machine tool architectures. The second step is an optimization step. Parameters are optimized to minimize the machine tool structure mass with a constraint of a minimal stiffness level. The third step concerns the dynamic performance

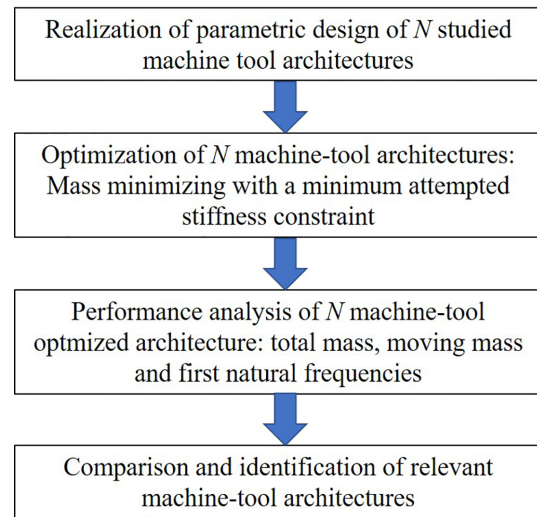

Figure 7: Machine tool architecture selection process.

evaluation of each optimized design through modal analysis. The final step allows classifying machine tool architectures by comparing their performances in terms of mass and modal frequencies.

A hollowed parallelepiped part, whose surfaces are meshed by shell elements, represents each substructure. Variables define the dimensions of these parts. Parametric optimization of the considered architectures is performed by coupling a constrained optimization algorithm (Matlab function “fmincon” with the interior-point algorithm) with finite element analysis (ANSYS) for mass minimization while respecting a minimum attempted stiffness. Finally, the optimized structures are compared and classified according to performance criteria.

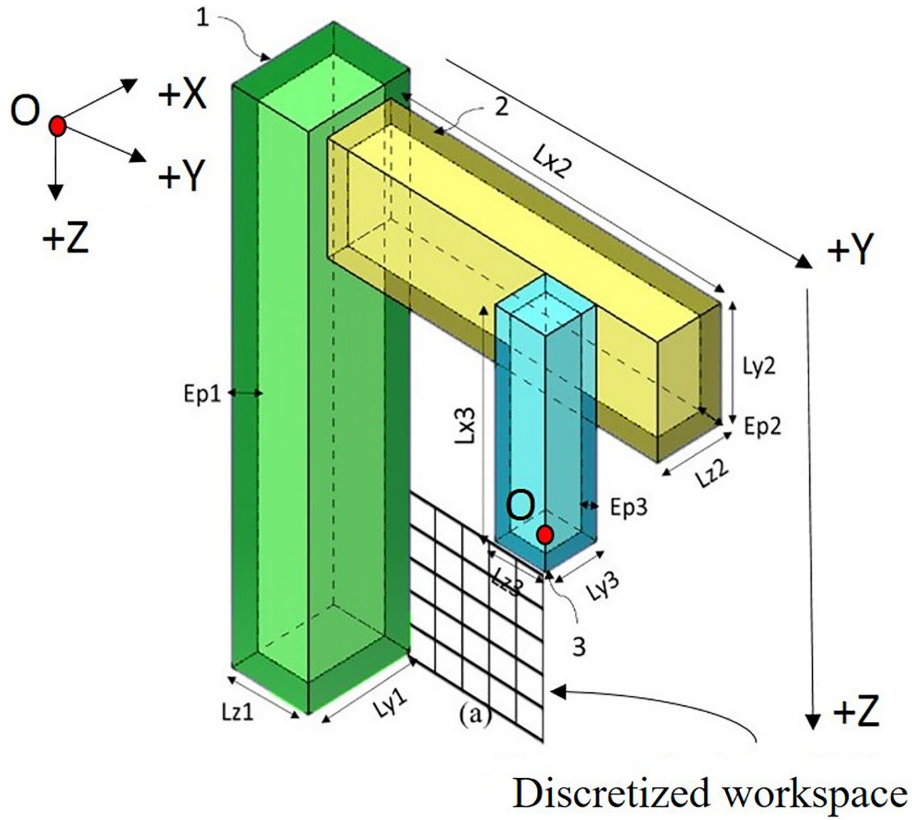

Figure 8: Example of discretization of machine tool workspace.

4.2. Performance criteria

For the optimization step, the cost function is the machine tool structure mass, and the constraint is the attempted minimum stiffness. However, stiffness varies regarding the position of the tool center point (TCP) position in the workspace. Thus, the minimum TCP stiffness value over all the workspace must be considered as a constraint function.

This minimum stiffness is computed from a static FE ANSYS analysis. Three load cases are applied, respectively, a force in each axis X, Y, and Z $[F_x, 0, 0]^t$, $[0, F_y, 0]^t$, and $[0, 0, F_z]^t$, and the computed displacements at the TCP are then transferred from ANSYS to Matlab environment. We denote by U_{xi} , U_{yi} , and U_{zi} the computed movements for a force applied in the i -axis direction ($i = x, y, z$). These simulations enable computing compliance and stiffness matrices at the TCP as detailed in equations (1) and (2).

$$[S] = \begin{bmatrix} \frac{U_{xx}}{F_x} & \frac{U_{xy}}{F_x} & \frac{U_{xz}}{F_x} \\ & \frac{U_{yy}}{F_y} & \frac{U_{yz}}{F_y} \\ \text{symm.} & & \frac{U_{zz}}{F_z} \end{bmatrix} \quad (1)$$

$$[K] = [S]^{-1} = \begin{bmatrix} K_{xx} & K_{xy} & K_{xz} \\ & K_{yy} & K_{yz} \\ \text{symm.} & & K_{zz} \end{bmatrix} \quad (2)$$

For a given pose of a machine tool, Bouzgarrou evaluated static performances at the TCP pose in all the space directions by using the stiffness ellipsoid (Bouzgarrou, 2001).

The eigenvalues of the stiffness matrix define this ellipsoid (equation (3)). These values represent the three lengths of the three principal axes of the ellipsoid. The minimum value of these eigenvalues is the minimum stiffness at the studied TCP pose.

$$[K_D] = \begin{bmatrix} K_1 & 0 & 0 \\ 0 & K_2 & 0 \\ 0 & 0 & K_3 \end{bmatrix} \quad (3)$$

This computation should be performed all over the workspace to find the minimum stiffness value of a machine tool structure. Thus, the TCP node is parameterized, and the machine tool pose is adapted.

The workspace is discretized with a step of 0.5 m to minimize the number of iterations during the optimization process (Fig. 8). The minimal stiffness is estimated from 25 different machine tool poses on the Y-Z plane at each optimization step. We adopt, at this design stage, as a hypothesis that the stiffness is nearly the same whatever the machine tool position along the x-axis is.

Figure 9 shows an example of a minimum stiffness map evaluated during an iteration step of the optimization. The red point is the minimum stiffness value over all the workspace.

After the optimization step, the optimized machine tool architecture model is used to evaluate more accurately the stiffness map, and the first natural frequency. The comparison of different optimized architectures can be realized regarding their respective total mass, mobile mass, and value of the first natural frequency.

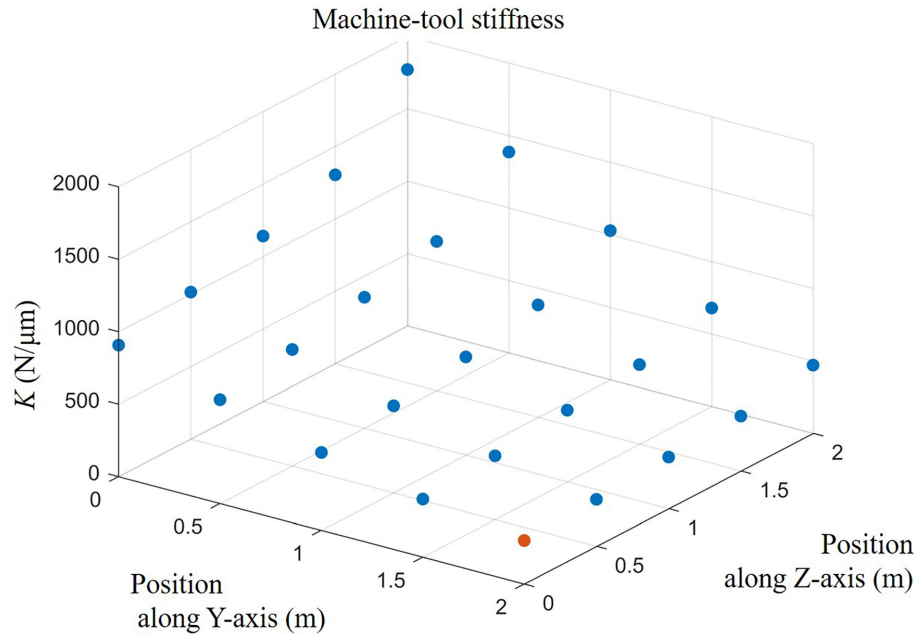

Figure 9: Minimal stiffness map computed during an iteration of the optimization.

Mimimize	$M_t = \rho V_t(\xi)$
Under the constraint	$K \geq K_{minimal}$ for $\xi_{min} \leq \xi \leq \xi_{max}$
With	<p>M_t: total mass of the structure</p> <p>K: structure stiffness</p> <p>$K_{minimal}$: minimum attempted stiffness</p> <p>V_t: total volume of the structure</p> <p>ρ: volumetric mass</p> <p>ξ: variable vector</p> <p>$\xi = [L_{y1} \ L_{z1} \ E_{p1} \ L_{y2} \ L_{z2} \ E_{p2} \ L_{y3} \ L_{z3} \ E_{p3}]$</p> <p>$\xi_{min} = [0.6 \ 0.6 \ 0.02 \ 0.5 \ 0.5 \ 0.02 \ 0.4 \ 0.4 \ 0.02]$</p> <p>$\xi_{max} = [1.5 \ 1.5 \ 0.15 \ 1.4 \ 1.4 \ 0.15 \ 1 \ 1 \ 0.15]$</p>

Figure 10: Optimization problem.

4.3. Summary

Performance criteria are evaluated in the preliminary design stage with a reduced mechanical model. The values associated with these criteria can be used to select relevant machine tool architecture regarding its structure mass for an attempted minimum stiffness. In the following section, this method is applied to compare open-loop and closed-loop machine tool architectures.

5. Comparison of Open-Loop and Closed-Loop Machine Tool Structures

Our optimization process consists of minimizing total mass for an attempted minimum stiffness. The design variables are L_{y1} , L_{z1} , and E_{p1} . A vector ξ collects all these variables. This vector is marked off by ξ_{min} and ξ_{max} . The optimization problem is formulated in Fig. 10.

The optimization process is realized for different attempted minimum stiffness from 100 to 500 N/μm. In this study, the compared structures have the same workspace ($z = 2$ m, $y = 2$ m), and

they are optimized to ensure the same minimum stiffness at the TCP.

The initial values of design variables are set to ξ_{max} . According to attempted stiffness, Table 1 gives the optimized design variable values. In the case of open-loop structure, the maximum sizes of the substructures 1 and 2 are reached for stiffness more than 200 N/μm. The increase in stiffness is then realized with an increase in thickness. In the case of closed-loop structure, the maximum box size is never reached.

Therefore, structure comparison is made regarding total mass, moving mass, and first natural frequency (Fig. 11). To validate the tendency of our results, we can argue that the closed-loop machine tool Forest-Liné Flexiax V weighs around 42 tons with all its equipment (Fives, 2017). This machine tool is designed to reach a stiffness of 500 N/μm. After our optimization process, a weight near 30 tons is found for a closed-loop machine tool architecture with a 500 N/μm stiffness.

The analysis of Fig. 11 shows that for a minimum stiffness higher than 100 N/μm, closed-loop machine tool architecture brings a benefit of performance. This conclusion is consistent with the developed industrial machine tool for titanium machining.

Table 1: Optimized design variables values.

Parameters (m)		L_{y1}	L_{z1}	E_{p1}	L_{y2}	L_{z2}	E_{p2}	L_{y3}	L_{z3}	E_{p3}
Open-loop machine tool structure										
Attempted stiffness (N/ μ m)	100	1.5	1.46	0.023	1.4	1.4	0.02	0.4	0.4	0.02
	200	1.5	1.5	0.043	1.4	1.4	0.027	0.4	0.4	0.03
	300	1.5	1.5	0.06	1.4	1.4	0.04	0.4	0.4	0.044
	400	1.5	1.5	0.078	1.4	1.4	0.053	0.4	0.4	0.056
	500	1.5	1.5	0.096	1.4	1.4	0.065	0.4	0.4	0.067
Closed-loop machine tool structure										
Attempted stiffness (N/ μ m)	100	0.77	0.6	0.02	1.1	0.533	0.02	0.4	0.4	0.02
	200	1.043	0.6	0.02	1.293	0.943	0.02	0.4	0.4	0.02
	300	1.067	0.868	0.02	1.328	0.966	0.02	0.4	0.4	0.02
	400	1.17	1.05	0.02	1.4	1.07	0.022	0.4	0.425	0.027
	500	1.19	1.15	0.026	1.3	1.09	0.022	0.4	0.545	0.03

Table 2: Structure ranking for a stiffness of 500 μ m.

Number of structures	1	2	3	4	5	6	7	8
Total mass (10^3 kg)	60	94.1	94.9	–	–	–	–	123.4
Ranking	1	2	2	–	–	–	–	3
Mobile mass along X (10^3 kg)	28	28	28	–	–	–	–	105
Ranking	1	1	1	–	–	–	–	2
Mobile mass along Y (10^3 kg)	6.9	26.15	25.94	–	–	–	–	13.3
Ranking	1	3	3	–	–	–	–	2
Mobile mass along Z (10^3 kg)	24.4	13.3	13.7	–	–	–	–	38.9
Ranking	2	1	1	–	–	–	–	3
First natural frequency (Hz)	29.5	29.3	30	–	–	–	–	27.7
Ranking	1	1	1	–	–	–	–	1
Ranking sum	6	8	8	–	–	–	–	11
Final ranking	1	2	2	–	–	–	–	3

This comparison validates the optimization process. The choice of a machine tool architecture for titanium alloy machining should be restricted to closed-loop architecture. However, for high stiffness machine tool, flexible joint behavior cannot be neglected. Thus, in the following section, we complete our modeling approach by introducing joint flexibility before the application on different kind of closed-loop architectures.

6. Improvement of Machine Tool Structures Models

Machine tool stiffness is due to the rigidity of all the elements (Huo & Cheng, 2009; Stephenson & Agapiou, 2016). It is necessary to consider parts and joints stiffness to compute static stiffness. Local springs can model joint stiffness (Fig. 12).

6.1. Joint stiffness modeling

The joint stiffnesses are estimated from manufacturer information. In this work, we choose to work with MRB 65 Schneeberger railway; thus, we extracted the stiffness information of this translational joint from Schneeberger (2020) (Fig. 13).

Schneeberger railway presents a different behavior according to the load direction. Three stiffness values are considered: a traction stiffness K_T , a compression stiffness K_C , and a lateral stiffness K_L . Equation (4) gives the values of these stiffnesses. However, to define simple joint modeling and improve the convergence robustness, we choose to take the same value for traction-compression stiffness K_{TC} . To avoid making an op-

timistic or pessimistic point of view, we consider the mean of K_T and K_C (equation (4)). The stiffness along the joint axis is the stiffness due to control law; we choose to define an arbitrary high stiffness value K_1 .

$$\begin{cases} K_C = 4138 \text{ N}/\mu\text{m} \\ K_T = 1920 \text{ N}/\mu\text{m} \\ K_L = 2116 \text{ N}/\mu\text{m} \\ K_{TC} = 3029 \text{ N}/\mu\text{m} \end{cases} \quad (4)$$

6.2. Results

In this paragraph, our methodology is applied to several closed-loop machine tool architectures for a workspace size of ($z = 2$ m, $y = 2$ m) and with the same values of ξ_{max} and ξ_{min} (Fig. 14).

Performance indicators are evaluated for minimum attempted stiffness of 500 N/ μ m. Optimized structures 4, 5, 6, and 7 cannot reach this minimum attempted stiffness of 500 N/ μ m. Thus, these structures are discarded.

Table 2 gives the values of the performance indicators. The analysis of this table shows that the structures 1, 2, and 3 are more relevant for milling titanium alloys. The mass values give an idea of each structure element size. Each structure optimization takes around 8 h. This time is consistent with the preliminary design stage.

Thus, with this study, we can discard five structures among eight from the preliminary design stage. The last choice of the relevant structure should now be realized after simulation with an accurate model of the final designed machine tools.

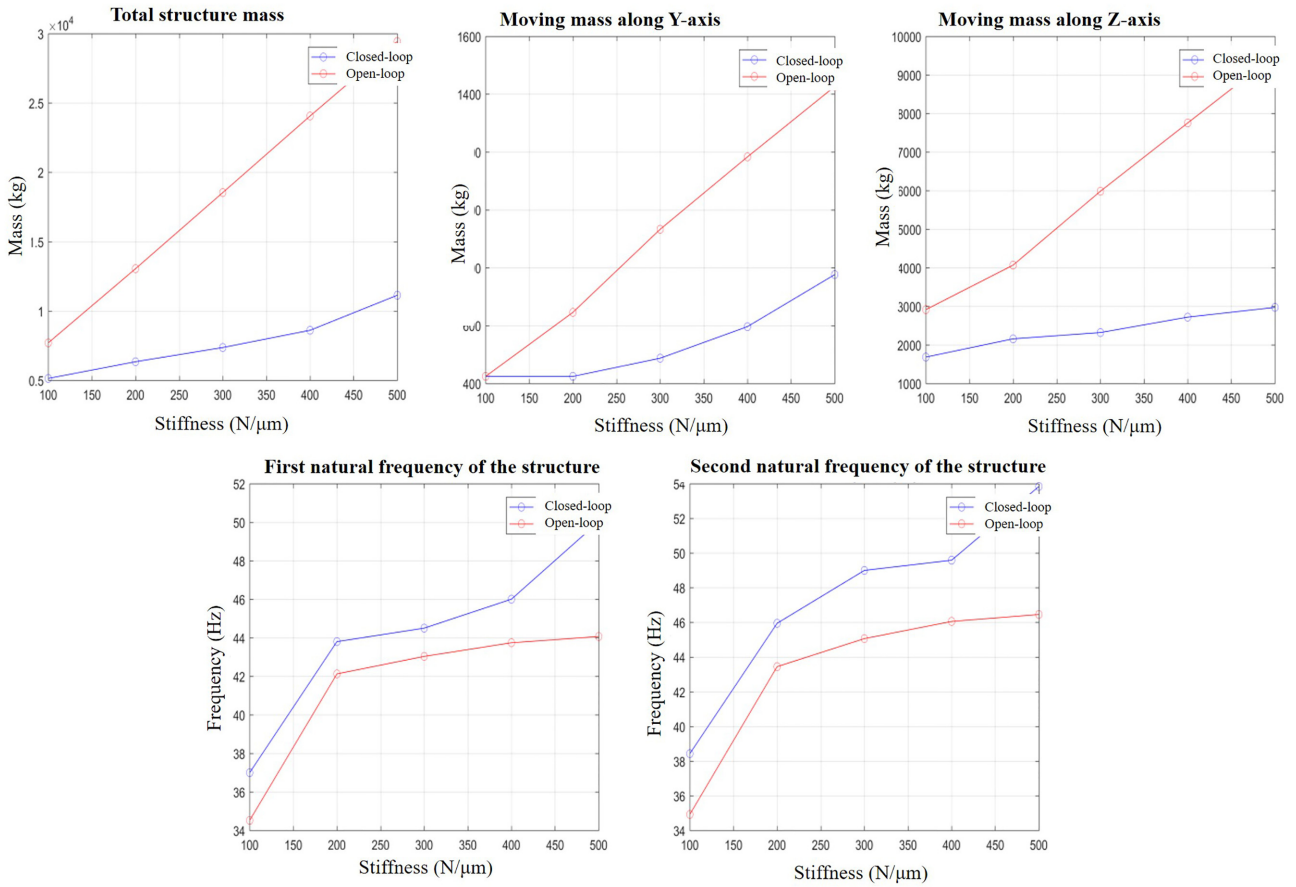

Figure 11: Comparison of performance criteria for open-loop and closed-loop machine tool architecture.

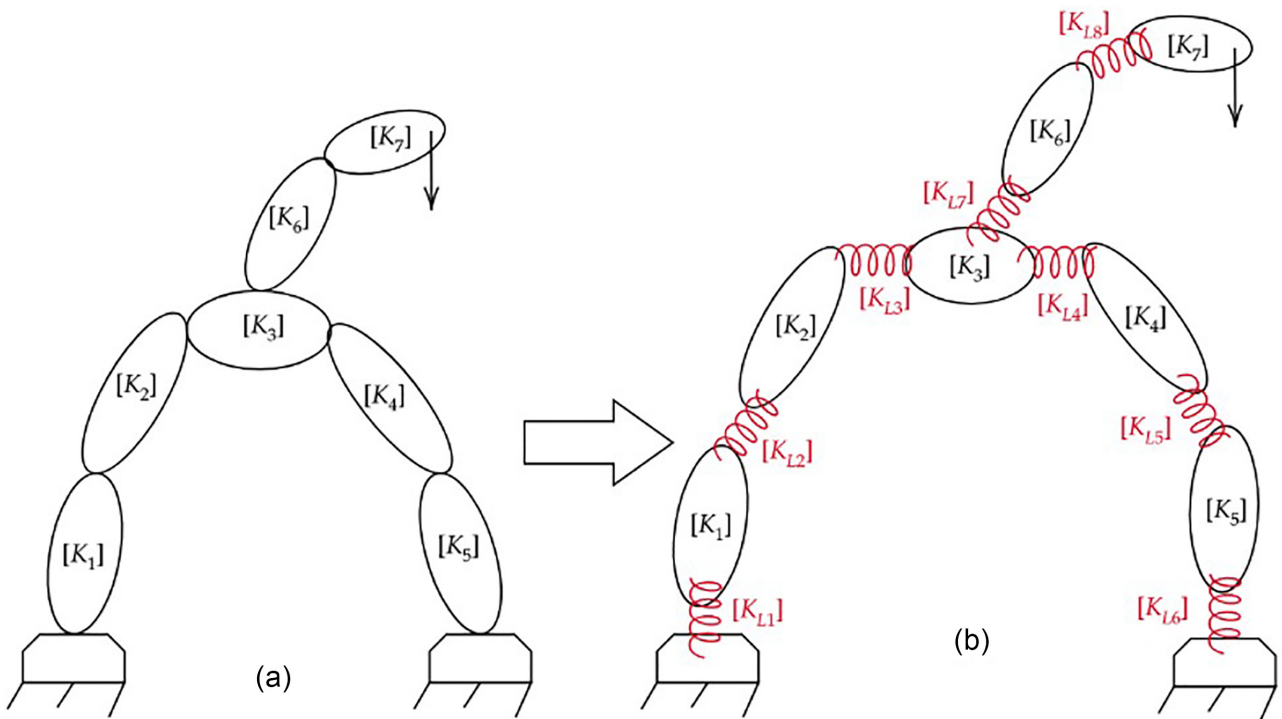

Figure 12: Modeling method of machine tool stiffness.

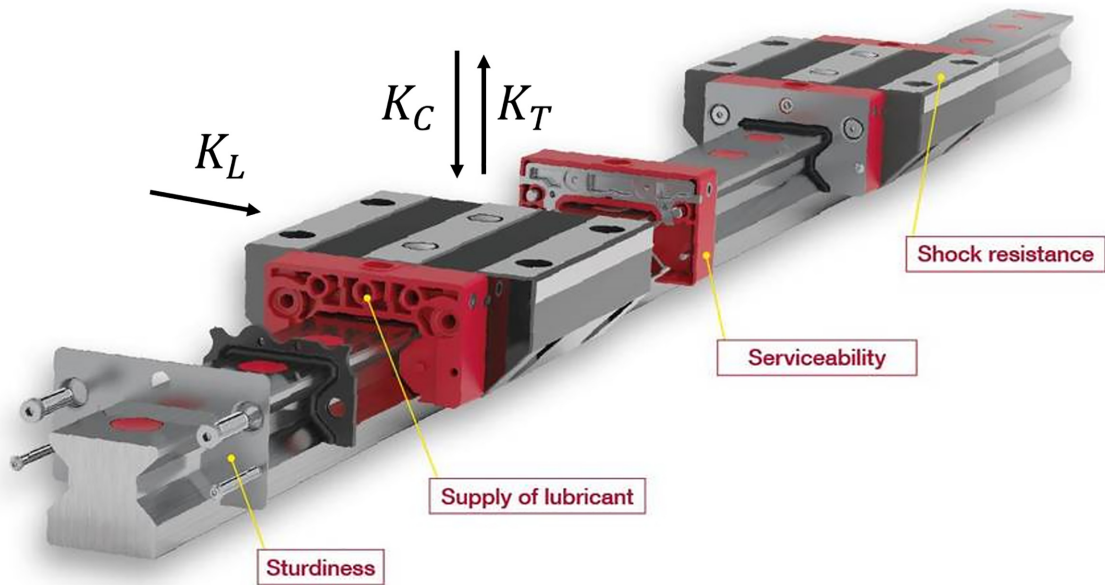

Figure 13: Linear railway with roller bearing (Schneeberger, 2020).

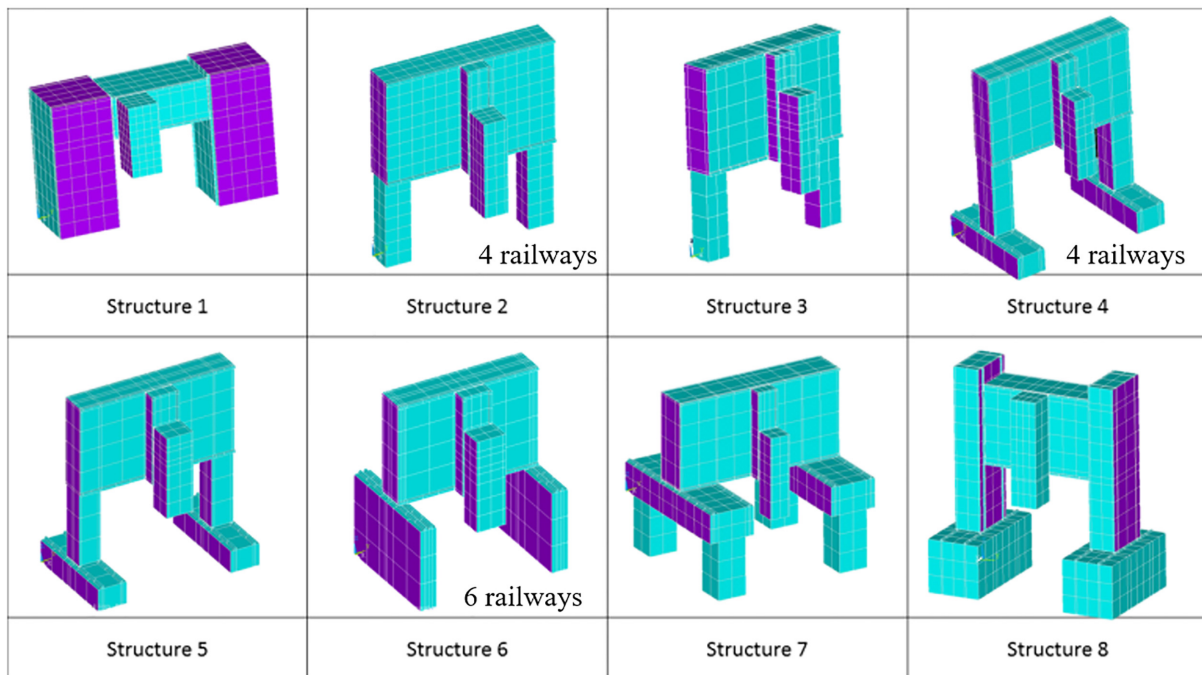

Figure 14: Compared closed-loop machine tool architecture.

7. Conclusion

This paper introduces an approach for machine tool architecture selection at the preliminary design stage. The proposed method is based on a structural optimization process applied to several candidate architectures described with reduced structural models. The design optimization algorithm has been implemented in Matlab, while ANSYS APDL has performed structural analyses with a parameterized structural model. The studied architectures have been classified according to their dynamic performances for a given stiffness. The proposed ap-

proach allows selecting relevant machine tool architectures in the preliminary design stage, which avoids costly detailed analyses of several design solutions. For titanium alloys machining application, it has shown that closed-loop architectures are the highest ranked. These results are in line with the current industrial choices. However, the architecture classification can be modified for application where the required levels of rigidity are lower than $500 \text{ N}/\mu\text{m}$.

From this preliminary work, a 5-axis machine tool can be designed by adding two rotational axis, thanks to Fig. 1. According

to technological data, rotational joint stiffness can be added to optimize and validate architecture stiffness.

Moreover, this work can be employed to study the impact of the used material for machine tool elements on stiffness and mass.

The methodology presented in this article complements the works introduced in the literature for designing a machine tool structure. It is a link between the methodologies of synthesis and choice of structural configurations (Chen, 2001; Heisel, Pasternak, Storchak, & Solopova, 2011), and structural mass/stiffness ratio optimization (Kono et al., 2010b; Portman et al., 2014).

Acknowledgement

This work belongs to the MMaSyF project (2015-2020) funded by the CPER Auvergne-Rhône-Alpes Region for the design and production of a high rigidity machine-tool. This work is co-financed by the European Union. Europe engages in Auvergne with the European Regional Development Fund (FEDER).

Conflict of interest statement

Declarations of interest: none.

References

- Altintas, Y., Brecher, C., Weck, M., & Witt, S. (2005). Virtual machine tool. *CIRP Annals – Manufacturing Technology*, 54(2), 115–138.
- Bouzgarrou, B. C. (2001). *Conception et modélisation d'une machine-outil à architecture hybride pour l'UTGV*. Université Blaise Pascal.
- Chanal, H., Duc, E., & Ray, P. (2006). A study of the impact of machine tool structure on machining processes. *International Journal of Machine Tools and Manufacture*, 46(2), 98–106.
- Chen, F.-C. (2001). On the structural configuration synthesis and geometry of machining centres. *Proceedings of the Institution of Mechanical Engineers, Part C: Journal of Mechanical Engineering Science*, 215(6), 641–652.
- Danhaive, R. A., & Mueller, C. T. (2015). Combining parametric modeling and interactive optimization for high-performance and creative structural design. In *International Association for Shell and Spatial Structures (IASS)*. Amsterdam, The Netherlands.
- Fives. (2017). The new titanium machining center Forest-Liné Flexiix V benefiting to the next generation of engineers. Retrieved February 18, 2020, from <https://www.fivesgroup.com/news-press/news/the-new-titanium-machining-center-forest-line-flexiix-v-benefiting-to-the-next-generation-of-engineers.html>.
- Heisel, U., Pasternak, S., Storchak, M., & Solopova, O. (2011). Optimal configurations of the machine tool structure by means of neural networks. *Production Engineering*, 5, 219–226.
- Hung, J. P., Lai, Y. L., Lin, C. Y., & Lo, T. L. (2011). Modeling the machining stability of a vertical milling machine under the influence of the preloaded linear guide. *International Journal of Machine Tools and Manufacture*, 51(9), 731–739.
- Huo, D., & Cheng, K. (2009). Basic concepts and theory. In K. Cheng (Ed.), *Machining Dynamics* (pp. 7–20). London: Springer. <https://doi.org/https://doi.org/10.1007/978-1-84628-368-0>.
- Inagaki, I., Takechi, T., Shirai, Y., & Ariyasu, N. (2014). Application and features of titanium for the aerospace industry. *Nippon Steel & Sumitomo Metal Technical Report*, 106(106), 22–27.
- Koenigsberger, F., & Tlustý, J. (1970). *Machine Tool Structures*. <https://doi.org/10.1016/b978-0-08-013405-5.50003-0>.
- Kono, D., Lorenzer, T., Weikert, S., & Wegener, K. (2010a). Comparison of rigid body mechanics and finite element method for machine tool evaluation. *ETH Zurich*. <https://doi.org/10.3929/ethz-a-006111492>.
- Kono, D., Lorenzer, T., Weikert, S., & Wegener, K. (2010b). Evaluation of modelling approaches for machine tool design. *Precision Engineering*, 34(3), 399–407.
- Lajili, M., Chanal, H., Bouzgarrou, C., & Duc, E. (2017). Méthodologie de choix d'une architecture de machine-outil 5 axes pour l'usinage du titane. In *23 ème Congrès Français de Mécanique*. Lille, France.
- Li, B., Hong, J., Wang, Z., Wu, W., & Chen, Y. (2012). Optimal design of machine tool bed by load bearing topology identification with weight distribution criterion. In *Procedia CIRP*, 3, 626–631. <https://doi.org/10.1016/j.procir.2012.07.107>.
- Maglie, P. (2012). Parallelization of design and simulation virtual machine tools in real product development. *ETH Zurich*. <http://doi.org/10.3929/ethz-a-007196640>.
- Maj, R., Modica, F., & Bianchi, G. (2006). Machine tools mechatronic analysis. *Proceedings of the Institution of Mechanical Engineers, Part B: Journal of Engineering Manufacture*, 220, 345–353. <https://doi.org/10.1243/095440505X32733>.
- Mekid, S. (2009). *Introduction to Precision Machine Design and Error Assessment*. Taylor & Francis.
- Mori, M., Piner, Z. I., Ding, K., & Hansel, A. (2008). Virtual evaluation for machine tool design. In *ASME 2008 9th Biennial Conference on Engineering Systems Design and Analysis* (pp. 489–493). Haifa, Israel. <https://doi.org/https://doi.org/10.1115/ESDA2008-59601>.
- Portman, V., Shneor, Y., Chapsky, V., & Shapiro, A. (2014). Form-shaping function theory expansion: stiffness model of multi-axis machines. *International Journal of Advanced Manufacturing Technology*, 76, 1063–1078.
- Rodrigues Henriques, V. A., de Campos, P. P., Alves Cairo, C. A., & Bressiani, J. C. (2005). Production of titanium alloys for advanced aerospace systems by powder metallurgy. *Materials Research*, 8(4), 443–446.
- Schneeberger. (2020). High-performance profiled guideways. Retrieved November 22, 2019, from <https://www.schneeberger.com>.
- Slavković, R., Veg, A., Nedeljko, D., Slavković, N., Baralić, J., & Miličević, I. (2015). Rigid body dynamics in optimization of the machine tool vibroisolation. *Tehnicki Vjesnik*, 22(1), 87–94.
- Stephenson, D. A., & Agapiou, J. S. (2016). *Metal Cutting Theory and Practice* (3rd ed.). Taylor & Francis.
- Wagner, V. (2011). *Amélioration de la productivité en usinage d'un titane réfractaire: le Ti5553*. Université de Toulouse. Retrieved from <http://ethesis.inp-toulouse.fr/archive/00001563/01/wagner.pdf>
- Zatarain, M., Lejardi, E., & Egaña, F. (1998). Modular synthesis of machine tools. *CIRP Annals – Manufacturing Technology*, 47, 333–336. [https://doi.org/10.1016/s0007-8506\(07\)62845-5](https://doi.org/10.1016/s0007-8506(07)62845-5).
- Zirn, O. (2008). Machine tool analysis modelling, simulation and control of machine tool manipulators. *ETH Zürich*. <https://doi.org/10.3929/ethz-a-005825192>
- Zulaika, J. J., Campa, F. J., & Lopez De Lacalle, L. N. (2011). An integrated process machine approach for designing productive and lightweight milling machines. *International Journal of Machine Tools and Manufacture*, 51(7–8), 591–604.